

Installation & Operations Manual Kawasaki Mule Pro Folding Windshield

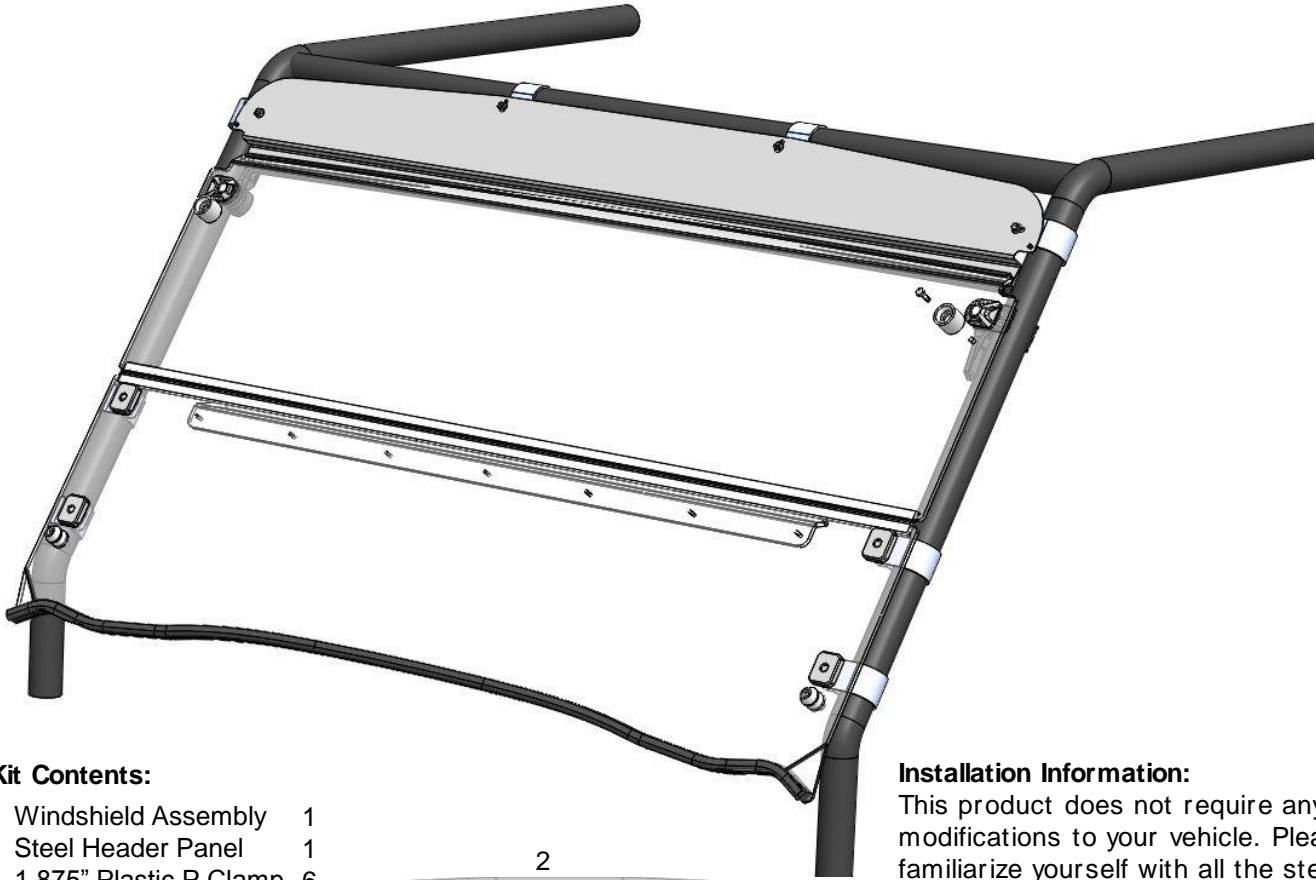

Kit Contents:

- 1) Windshield Assembly 1
- 2) Steel Header Panel 1
- 3) 1.875" Plastic P Clamp 6
- 4) 1.75" Plastic P Clamp 2
- 5) Finishing Block 4
- 6) Plastic Spacer 2
- 7) Windshield Lever 2
- 8) Windshield Plug 2
- 9) M6 x 20 Flange Bolt 2
- 10) M6 x 45 Flange Bolt 2
- 11) M6 x 30 Hex Bolt 4
- 12) M6 Nyloc Flange Nut 8
- 13) 55" Upper Gasket 1
- 14) 59" Lower Gasket 1

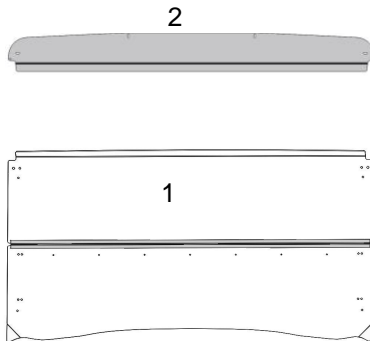

Installation Information:

This product does not require any modifications to your vehicle. Please familiarize yourself with all the steps before beginning assembly.

Compatibility Info:

This windshield is designed to work with other Seizmik branded Accessories for the Kawasaki Mule Pro as well as OEM Kawasaki hard tops. Please note Seizmik cannot guarantee fitment with other branded aftermarket products. Please research installation details on our products and others when trying to combine different branded accessories.

Seizmik makes Windshields, Mirrors, Door Kits, Light Bars, Hood Racks, and other great accessories for UTV's to maximize the vehicles usefulness. To help you do what you do better.

If you have any questions, comments, need assistance, or are missing parts, please visit our website <http://seizmik.com/customer-support> Or email us at service@seizmik.com. Visit www.seizmik.com for more information on our product or call 1-866-838-3366 between 9:00AM and 5:00PM EST.

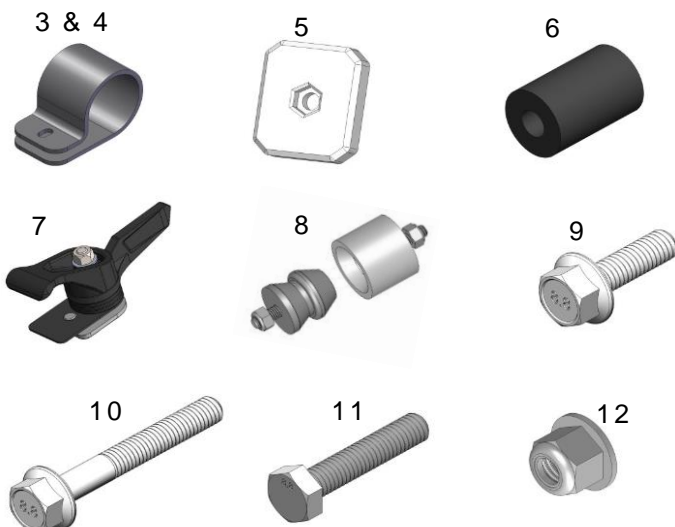

Header Panel Installation:



1. In the approximate locations shown, Snap 3 1.875" Plastic P Clamps on each side of the roll cage. The flanges will point forward and towards the center. Snap the smaller 1.75" clamps on the upper cross tube with the flanges forward and down.



2. Holding the steel header panel in place with the flange facing IN, loosely bolt in place on each end using the M6X20 flange bolts and nyloc nuts as shown in step 3.

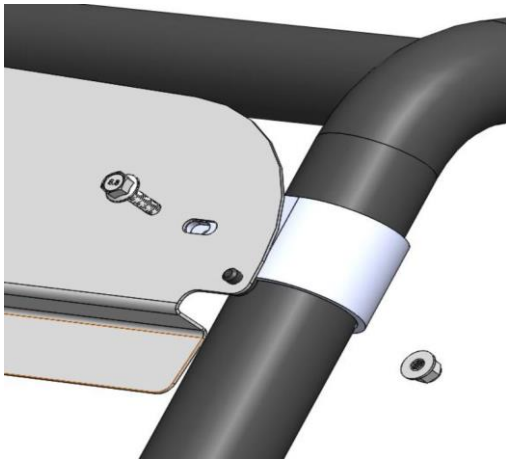

3. Bolt loosely in place using the M6x20 flange bolts and nyloc nuts.



4. Bolt the header panel loosely to the upper crossbar using the M6x45 flange bolts, plastic spacers and nuts. Leave all header panel fasteners slightly loose so you can adjust its position after the windshield is in place.

Windshield Assembly:

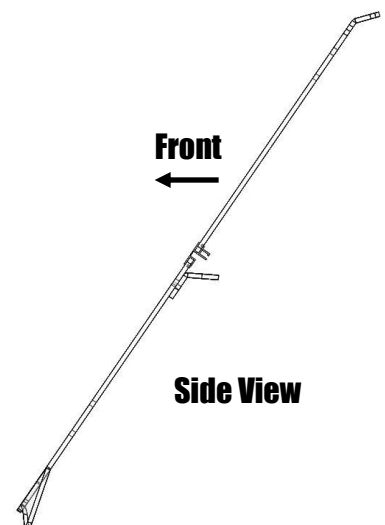
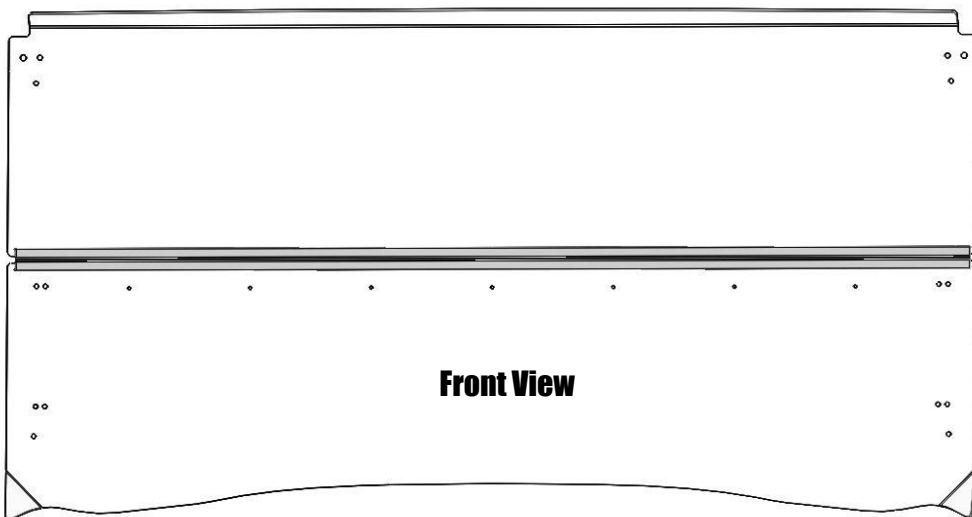

Windshield Assembly:

1. Assemble the windshield levers. The handle on the lever can be "clocked" in 4 different positions. Make sure they are assembled as shown. Tighten the nut so that the thick rubber washer is compressed slightly. Assemble the upper windshield holders on the front face of the windshield as shown. Repeat both steps for other side.

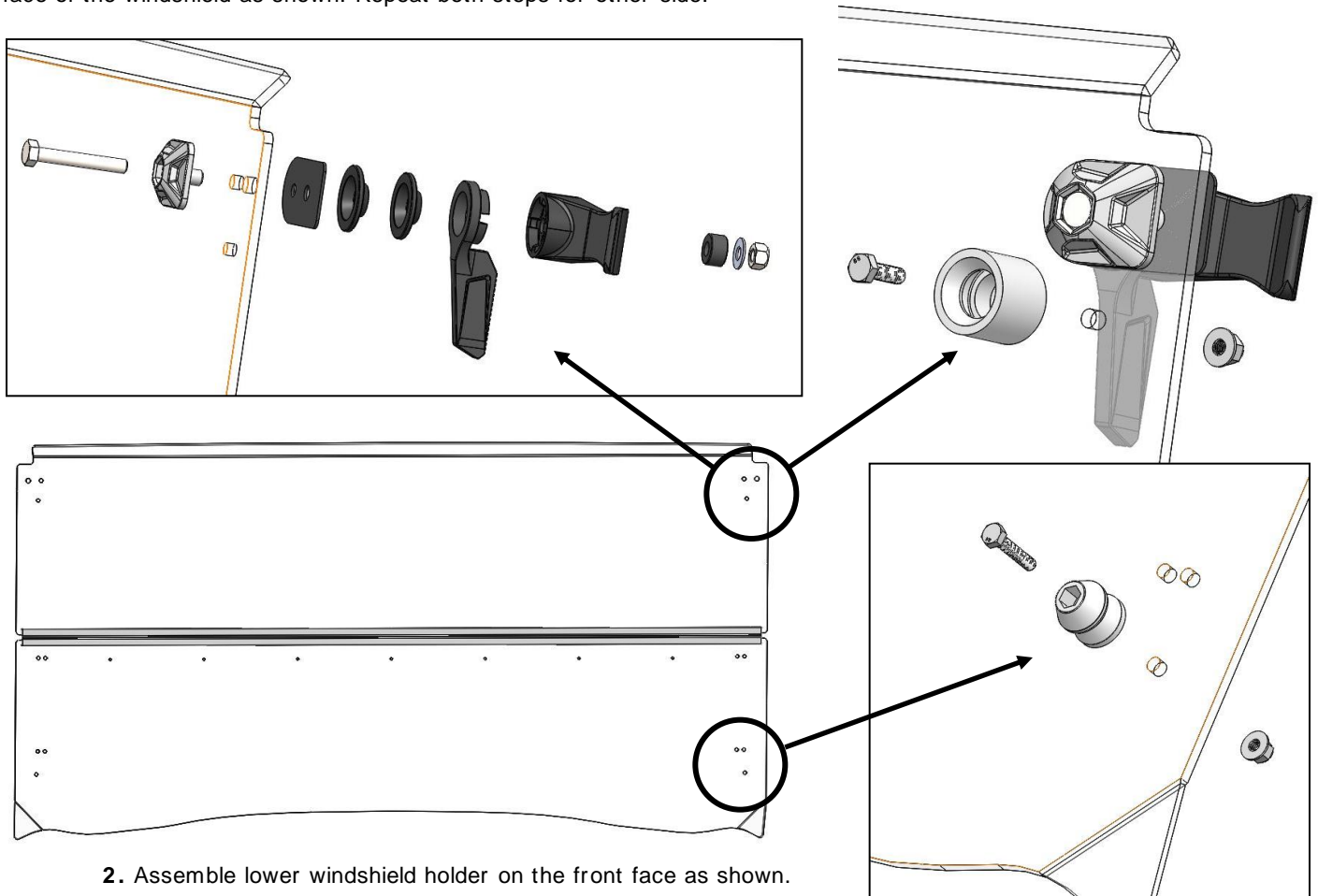

2. Assemble lower windshield holder on the front face as shown.

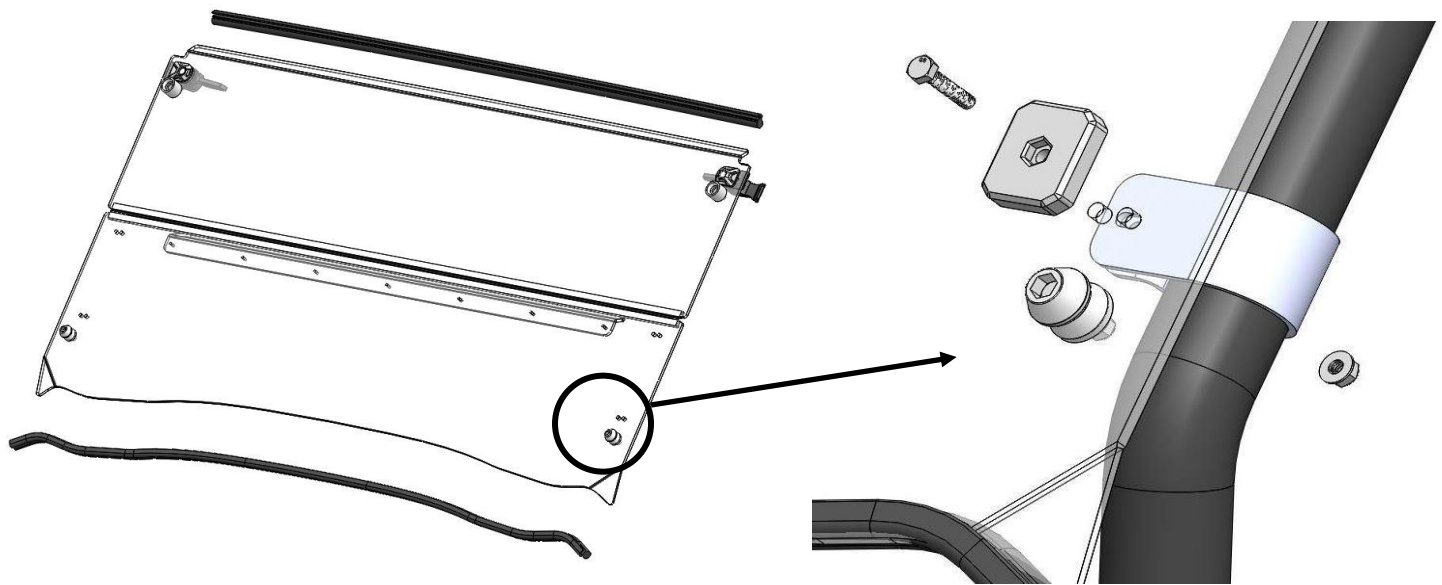

3. Push the 55" upper gasket onto the top flange of the windshield with the bulb of the gasket facing back. Push the 59" gasket onto the bottom of the windshield with the bulb facing back.

4. Resting the windshield on the hood of the vehicle, adjust the clamp locations to line up with the mounting holes. Attach windshield using the M6x30 hex bolts, finishing blocks, and nyloc nuts. Make sure the windshield is firmly seated on the hood and that the upper gasket is sealing on the steel header panel before tightening all bolts.